



C500-I

P Y R O L Y S I S B O I L E R

HEAT THAT SAVES THE CLIMATE

Information:

Except water, soil and atmosphere, biomass is the most important global CO₂ storage/sink. The conventional energetic use of local biomass releases as much CO₂ as was previously bound by the biomass. In contrast, BIOMACON technology essentially only uses the hydrogen contained in the biomass for energy purposes. Chemically stable carbon is systematically decoupled as biochar.

Production of biochar from sustainable biomass sources is an important component within the fight against climate change. One kilogram of pure biochar binds 3.6 kg of CO₂ for more than 1.000 years. Moreover, the application of biochar in agriculture is a powerful tool against soil desertification. Water and groundwater are actively protected when nitrate-containing fertilizers are replaced by biochar.

The BIOMACON pyrolysis boilers provide an integral system for the effective use of all available resources.

- BIOMACON Pyrolysis Boilers are designed for ligno-cellulosic raw materials with a maximum water content of 30%.
- The space requirement of the Pyrolysis Boilers is low. This makes the integration into existing buildings easy.
- The compact design ensures maximum heat utilization. The radiation losses are low.

BIOMACON Pyrolysis Boilers are heatdriven and designed according to the required heat demand. They are therefore available in various sizes from 40-500kW. The power control is modulating and automatically adapts to the required heat demand in a wide load range.

Technical Data:

Trade name:	Pyrolysis Boiler
Nominal thermal power:	500kW
Weight:	28.125kg
Heat exchanger water vol.:	7.312Liter
Max. operation pressure:	2,8bar
Max. permissible operating temp. in the converter:	900°C
Max. permissible operating temp. in the combustion chamber:	850°C
Rated voltage / current::	400V/32A
EL. power consumption:	3.500W

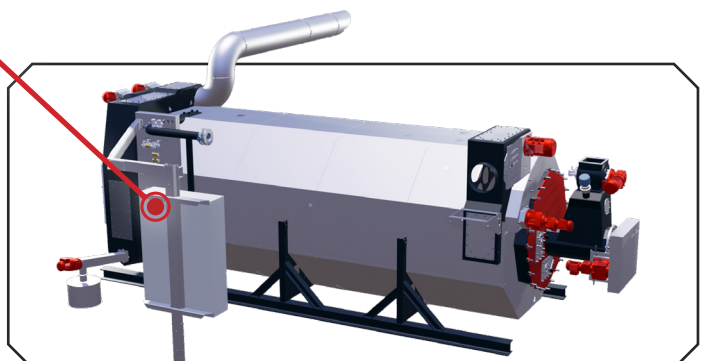

C500-I

Pyrolysis Boiler

Technical Drawing:

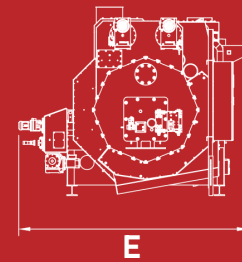
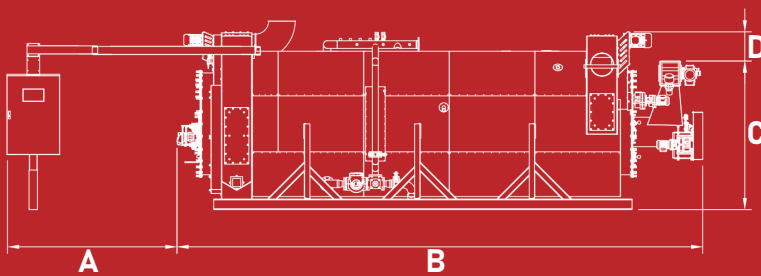

	Dim. in mm:
A	2.583
B	8.985
C	2.255
D	442
E	3.492

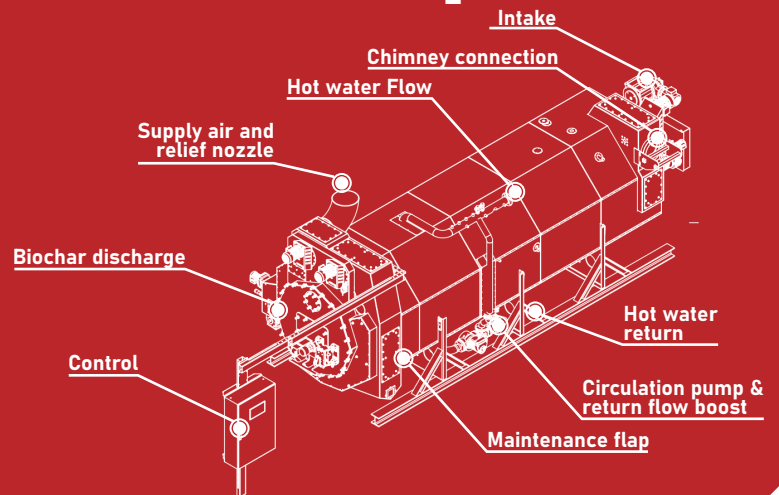

Application Example:

Baseline::

Solid fuel:	Wood chips (pine)
Water content:	20%
Ash content:	2%
Full load hours:	8.000

Model	Solid fuel intake [t/a]	Solid fuel intake [kg/h]	Biochar discharge [t/a]	Biochar discharge [kg/h]	Nominal thermal power [kW]	CO2 equivalent storage [t/a] (1kgC:3,6kgCO ₂)-20% loss
C500-I	2.360	295	453	64	500	1.305

*Information depends on other process parameters and is therefore not guaranteed

